

Sealed Thermospray Water Spray Nozzle

Technical Specification

RTI-Value:	~ 100 (metric) (Standard A)
Weight:	66g (Brass)
The	1/2" BSPT (NPT also available)
Maximum Working Pressure:	12.5 Bar
System Test Pressure:	20 Bar

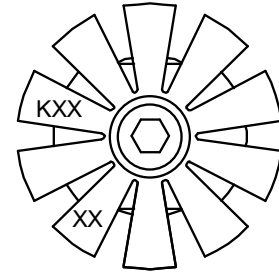

Ordering Example:
See table below. Write D4 followed by code for K-factor, material, finish, deflector angle, temperature & thread.

e.g.
D41200ACB
Sealed Thermospray 12mm, brass, 60°C, 68°C, BSP

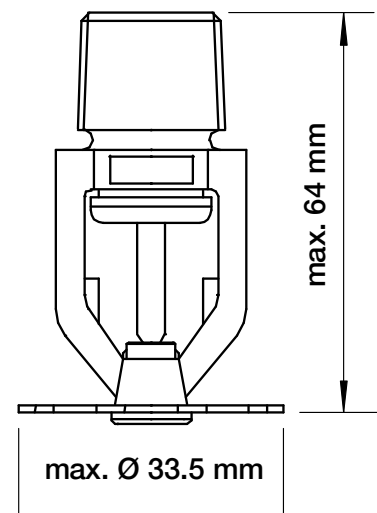

Options

K Factor (±5%) :	17	29	46	76		
Bore mm:	6	8	10	12		
Code:	06	08	10	12		
Material:	Brass	SS316	SMO 254			
Code:	0	2	9			
Finish:	Natural	ENP17	ENP40			
Code:	0	2	4			
Deflector Angles:	60°	90°	120°	150°		
Code:	A	C	F	H		
Operating Temperature °C	57°	68°	79°	93°	141°	182°
Code:	B	C	D	E	F	G
Thread 1/2"	BSPT	NPT (on request)				
Code:	B	N				

Rapidrop Limited

Rutland Business Park, Newark Road, Peterborough, PE1 5WA, United Kingdom

Tel: +44 (0) 1733 847 510 Fax: +44 (0) 1733 553 958

e-mail: rapidrop@rapidrop.com web: www.rapidrop.com