



ALARM CHECK VALVE
3", 4" & 6" MODEL H-1
FLANGE/FLANGE
3" & 4" MODEL H-2
GROOVE/GROOVE
3", 4" & 6" MODEL H-3
FLANGE/GROOVE

DESCRIPTION AND OPERATION

The Globe Model H-1, H-2 and H-3 Alarm Check Valves are used in wet pipe fire sprinkler systems. They primarily serve a dual purpose in that they prevent a reverse flow of water through their bodies (non-return) and also provide for the use of a hydraulic fire alarm which is not dependent upon an electrical power supply for its operation. Through the use of a hydraulic retard chamber a time delay is provided to eliminate potential false alarms caused by fluctuating water supply pressures. Where constant pressure water supplies are used the retard chamber (time delay) is not necessary. By incorporating the use of electrical pressure switches, other supplemental alarms, annunciators etc. may also be used.

A unique feature found on the Globe 3", 4" and 6" Alarm Valves is the clapper being hinged to the handhole cover for extreme ease of removal for inspection and service.

Globe Model H-1, H-2 and H-3 Alarm Check Valves may be installed in both vertical and horizontal positions and trim can be provided for both variable and constant water supply pressures in either of these positions.

The body of the Alarm Check Valve is constructed of high tensile strength cast iron having considerable ductility to reduce damage in field handling.

All interior operating parts are machined from highly corrosive-resistant alloys, each having high strength and good wear resistance.

Rubber parts are of selective materials which have good abrasive resistance and long life expectancy in terms of resiliency.

APPROVALS

- cULus Listed
- LPCB Approved
- FM Approved
- NYC - DOB MEA 325-91-M

TECHNICAL DATA

- Water Working Pressure Rating - 175 psi (12 bars) (see below for more specific rating approvals).
- 4" Model "H-1" cULus Listed with D.I.N. Class 16 flanges has a pressure rating of 16 bars.
- 4" and 6" Model "H-1" LPCB Approved for a 16 bar pressure rating with DIN Class 16 flanges.
- Factory tested hydrostatically at twice the rated working pressure.
- Equivalent feet of pipe: 3" Valve = 12.2 feet, 4" Valve = 9.7 feet, 6" Valve = 17 feet.



MODEL H-1



MODEL H-2



MODEL H-3

PHYSICAL DATA	MODEL / SIZE							
	H-1			H-2		H-3		
	3"	4"	6"	3"	4"	3"	4"	6"
Overall Length	9"	9"	10"	10"	10"	9 ¼"	9 ½"	11"
Weight of Valve	34 lbs.	42 lbs.	69 lbs.	20 lbs.	22 lbs.	28 lbs.	37 lbs.	59 lbs.
Complete with Vertical Variable Pressure Trimmings	81 lbs.	89 lbs.	114 lbs.	57 lbs.	69 lbs.	75 lbs.	84 lbs.	100 lbs.

ALARM CHECK VALVE

3", 4" & 6" MODEL H-1 FLANGE/FLANGE

3" & 4" MODEL H-2 GROOVE/GROOVE

3", 4" & 6" MODEL H-3 FLANGE/GROOVE

MODEL H-1 CROSS SECTIONS

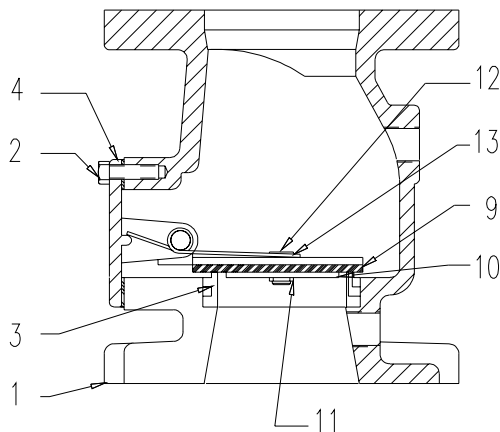

LEFT SIDE VIEW

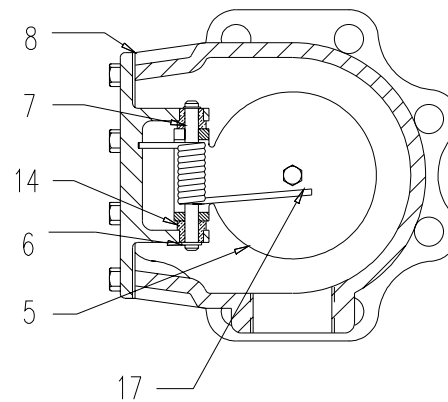

TOP VIEW

ITEM	DESCRIPTION	MAT'L	3" P/N	4" P/N	6" P/N	ITEM	DESCRIPTION	MAT'L	3" P/N	4" P/N	6" P/N
1	Body - H-1	Cast Iron	323803	323502	323562	9	Clapper Facing Disc	EPDM	323815	323511	323571
	Body H-2	Cast Iron	323827	323552	-----	10	Disc Retainer	Stainless	323816	323512	323572
	Body - H-3	Cast Iron	323807	323542	323592	11	Lock Nut	Stainless	323514	323514	323514
2	Cover Bolt	Steel	323408	323509	323569	12	Disc Retainer Bolt	Stainless	323817	323513	323573
3	Seat Ring	Bronze	323809	323504	323564	13	Sealing Washer	Hard Fiber	323515	323515	323515
4	Cover	Cast Iron	323805	323507	323567	14	Hinge Pin Bushing	Bronze	323819	323518	323518
5	Clapper	Stainless	323814	323510	323570	15	Name Plate	Aluminum	323480	323480	323480
6	Retaining Ring	Stainless	323527	323517	323517	16	Drive Screw	Stainless	323520	323520	323520
7	Hinge Pin	Stainless	323818	323516	323516	17	Torsion Spring	Stainless	323528	323528	323565
8	Cover Gasket	Vellumoid	323810	323508	323568	18	Spring Bushing	Brass	-----	-----	323579

Refer to Globe's Alarm Check Valve Installation and Maintenance Guide (Bulletin A.C.V.I.M.) for trim set-up, installation instructions, and maintenance.

ORDERING INFORMATION

SPECIFY

- Quantity • Model Number • Size
- Factory Trimmed and Leak Tested Hydrostatically or Loose Trim for Customer Installation.

GLOBE® PRODUCT WARRANTY

Globe agrees to repair or replace any of its own manufactured products found to be defective in material or workmanship for a period of one year from date of shipment.

For specific details of our warranty please refer to Price List Terms and Conditions of Sale (Our Price List).



4077 AIRPARK DRIVE, STANDISH, MICHIGAN 48658

989-846-4583

1-800-248-0278

FAX 989-846-9231

www.globesprinkler.com