



**EXTENDED COVERAGE
AUTOMATIC SPRINKLERS
MODEL GL8128, GL8129, GL8174
HORIZONTAL SIDEWALL**

DESCRIPTION AND OPERATION

The Globe Models GL8128, GL8129 and GL8174 Extended Coverage Horizontal Sidewall Sprinklers are a low profile yet durable design which utilizes a 3mm frangible glass ampule as the thermosensitive element. While the sprinkler provides an aesthetically pleasing appearance, it serves to protect various area coverages and should be installed in accordance with NFPA 13. This sprinkler series is available in various temperature ratings and several finishes to meet many varying design requirements.

The heart of Globe's GL Series sprinkler proven actuating assembly is a hermetically sealed frangible glass ampule that contains a precisely measured amount of fluid. When heat is absorbed, the liquid within the bulb expands increasing the internal pressure. At the prescribed temperature the internal pressure within the ampule exceeds the strength of the glass causing the glass to shatter. This results in water discharge which is distributed in an approved pattern.

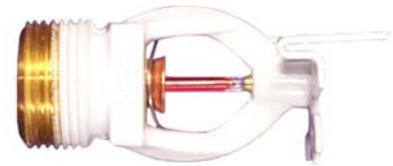

**EXTENDED COVERAGE
HORIZONTAL SIDEWALL**

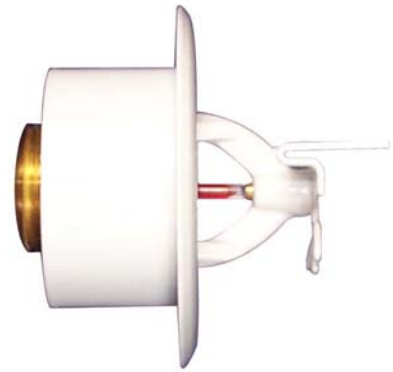

**RECESSED
EXTENDED COVERAGE
HORIZONTAL SIDEWALL**

TECHNICAL DATA

- See reverse side for Approvals and Specifications.
- Temperature Rating - 135°F (57°C), 155°F (68°C), 200°F (93°C).
- Water Working Pressure Rating - 175 psi (12 Bars).
- Factory tested hydrostatically to 500 psi (34 Bars).
- Maximum low temperature glass bulb rating is -67°F (-55°C).
- Frame - bronze • Deflector - brass • Screw - brass
- Bulb seat - copper • Spring - nickel alloy • Seal - teflon
- Bulb - glass with alcohol based solution, 3mm size.
- Escutcheon Assembly - steel

• SPRINKLER TEMPERATURE RATING/CLASSIFICATION and COLOR CODING

CLASSIFICATION	AVAILABLE SPRINKLER TEMPERATURES		BULB COLOR	N.F.P.A. MAXIMUM CEILING TEMPERATURE	
ORDINARY	135°F/155°F	57°C/68°C	ORANGE/RED	100°F	38°C
INTERMEDIATE	200°F	93°C	GREEN	150°F	66°C

EXTENDED COVERAGE AUTOMATIC SPRINKLERS MODEL GL8128, GL8129, GL8174 HORIZONTAL SIDEWALL

SPECIFICATIONS

NOMINAL "K" FACTOR	THREAD SIZE	LENGTH	FINISHES
8.1 (116 metric)	3/4" NPT	3" (7.6 cm)	Factory Bronze *Satin Chrome Bright Chrome White Polyester+ Black Polyester+ *Lead Coated

NOTE: METRIC CONVERSIONS ARE APPROXIMATE.

*FINISHES AVAILABLE ON SPECIAL ORDER.
+AVAILABLE AS cULus LISTED CORROSION RESISTANT WHEN SPECIFIED ON ORDER.

APPROVALS

STYLE	SIN MODEL	K FACTOR	135°F 57°C	155°F 68°C	cULus	NYC - DOB MEA 101-92-E
SIDEWALL	GL8128	8.1	---	X	X	X
	GL8129		---	X	X	X
	GL8174		X	---	X	X

U.L. LISTING DESIGN - USE REQUIREMENTS FOR LIGHT HAZARDS

SIN MODEL	STYLE	TEMP.	CEILING TO DEFLECTOR DISTANCE	WIDTH OF COVERAGE	LENGTH OF COVERAGE	MIN. PRESSURE P.S.I.	FLOW IN G.P.M.
GL8128 GL8129	Standard & Recessed	135°F / 57°C 155°F / 68°C **200°F / 93°C	4" TO 6" 6" TO 12	16'	16'	QR Models Shown on Page A-46	
					18'		
					20'	16.6	33
					22'	20.8	37
					*24'	26.8	42
GL8174	Standard & Recessed	135°F / 57°C	12" TO 18"	16'	16'	12.0	28
					18'	14.6	31
					20'	18.7	35
					22'	20.8	37

* 24' COVERAGES NOT LISTED FOR RECESSED INSTALLATIONS.

**200°F SPRINKLER NOT LISTED FOR 16' x 22' OR 16' x 24'.
MINIMUM 6' SPRINKLER SPACING.

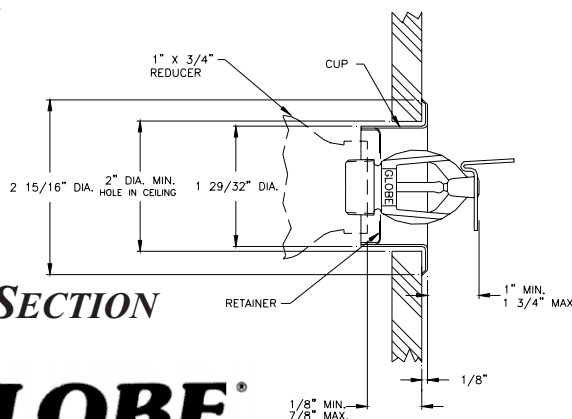

CROSS SECTION



ORDERING INFORMATION

SPECIFY

- Quantity • Model Number • Style
- Orifice • Temperature • Finishes desired
- Quantity - Wrenches - P/N 312366
- Quantity - Recessed Wrenches - P/N 325401, Rev. D
- Quantity - Protective Caps - P/N 327109-CAP (Friction Fit Recessed)

GLOBE® PRODUCT WARRANTY

Globe agrees to repair or replace any of its own manufactured products found to be defective in material or workmanship for a period of one year from date of shipment.

For specific details of our warranty please refer to Price List Terms and Conditions of Sale (Our Price List).

4077 AIRPARK DRIVE, STANDISH, MICHIGAN 48658

989-846-4583

FAX 989-846-9231

1-800-248-0278

www.globesprinkler.com