



QUICK RESPONSE
AUTOMATIC SPRINKLERS
GL SERIES
CONCEALED PENDENT

DESCRIPTION AND OPERATION

The Globe Quick Response GL Series Concealed Pendent Sprinkler is a low profile, aesthetically pleasing design. It provides sprinkler operation approximately six times faster than ordinary sprinklers and can be installed wherever standard concealed spray sprinklers are specified when allowed by the applicable standards. It offers the additional feature of greatly increased safety to life and should be used advisedly and under the direction of approving authorities having jurisdiction. The Sprinkler is available with 1/8" adjustment and a low profile cover plate assembly. All that is seen at the ceiling is a 3 5/16" diameter ceiling plate color finished to match the specifier's exact requirements. The GL Series Concealed Sprinkler may be virtually invisible as it does not interrupt the "smooth flow" of the ceiling. Globe's Concealed Sprinkler utilizes its 3mm frangible glass ampule type sprinkler which is located above the ceiling and concealed from view by the ceiling plate. The ceiling plate is soldered to the sprinkler's special upper support assembly in three places. Upon the application of sufficient heat, the plate falls to the floor exposing the quick response pendent spray sprinkler. At the ampule's rated temperature, the sprinkler opens discharging water onto the floor in its required and approved distribution pattern.

A special spring is attached to the pendent sprinkler deflector that serves to provide a constant tension against the ceiling plate. This feature virtually ensures freedom from environmental vibration problems.

TECHNICAL DATA

- See reverse side for Approvals and Specifications.
- Temperature Ratings -
 - 135°F (57°C) Sprinkler, 135°F (57°C) Cover Plate;
 - 155°F (68°C) Sprinkler, 135°F (57°C) Cover Plate
 - 175°F (79°C) Sprinkler, 155°F (68°C) Cover Plate;
 - 200°F (93°C) Sprinkler, 155°F (68°C) Cover Plate.
- Water Working Pressure Rating - 175 psi (12 Bars).
- Factory tested hydrostatically to 500 psi (34 Bars).
- Maximum low temperature glass bulb rating is -67°F (-55°C).
- Frame - bronze • Deflector - brass • Screw - brass
- Bulb seat - copper • Spring - nickel alloy • Seal - teflon
- Bulb - glass with alcohol based solution, 3mm size.
- Cover Plate - brass
- Upper Escutcheon Assembly - steel



QUICK RESPONSE
WHITE
CONCEALED PENDENT

• SPRINKLER TEMPERATURE RATING/CLASSIFICATION and COLOR CODING

CLASSIFICATION	AVAILABLE SPRINKLER TEMPERATURES		BULB COLOR	N.F.P.A. MAXIMUM CEILING TEMPERATURE	
ORDINARY	135°F/155°F	57°C/68°C	ORANGE/RED	100°F	38°C
INTERMEDIATE	175°F/200°F	79°C/93°C	YELLOW/GREEN	150°F	66°C

QUICK RESPONSE AUTOMATIC SPRINKLERS GL SERIES CONCEALED PENDENT

SPECIFICATIONS

NOMINAL "K" FACTOR		THREAD SIZE	LENGTH	FINISHES
2.8	(39 metric)	1/2" NPT	2 1/2" (6.4 cm)	Bright Chrome White Painted
4.2	(59 metric)	1/2" NPT		*Satin Chrome *Bright Brass
5.6	(80 metric)	1/2" NPT		*Other Painted Finishes

NOTE: METRIC CONVERSIONS ARE APPROXIMATE.

* FINISHES AVAILABLE ON SPECIAL ORDER.
PAINTED PLATES OTHER THAN WHITE REQUIRE
CUSTOMER TO FURNISH PAINT.

APPROVALS

STYLE	SIN MODEL	K FACTOR	135°F (57°C)	155°F (68°C)	175°F (79°C)	200°F (93°C)	cULus
			WITH PLATE 135°F (57°C)	WITH PLATE 135°F (57°C)	WITH PLATE 155°F (68°C)	WITH PLATE 155°F (68°C)	
CONCEALED PENDENT	GL2804	2.8	X	X	X	X	X
	GL4204	4.2	X	X	X	X	X
	GL5604	5.6*	X	X	X	X	X

*LISTED FOR ALL HAZARDS.

CROSS SECTION

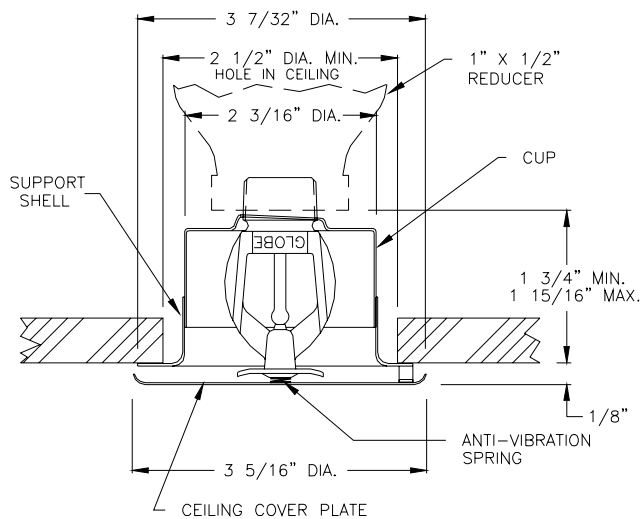

1/8" ADJUSTMENT



ORDERING INFORMATION

SPECIFY

- Quantity • Model Number • Style
- Orifice • Thread Sizes • Temperature
- Finishes desired
- Quantity - Concealed Wrenches - P/N 325391
- Quantity - Protective Caps - P/N 327119

GLOBE® PRODUCT WARRANTY

Globe agrees to repair or replace any of its own manufactured products found to be defective in material or workmanship for a period of one year from date of shipment.

For specific details of our warranty please refer to Price List Terms and Conditions of Sale (Our Price List).

4077 AIRPARK DRIVE, STANDISH, MICHIGAN 48658

989-846-4583

FAX 989-846-9231

1-800-248-0278

www.globesprinkler.com